

**SPANESI AMERICAS
ALUMINUM REPAIR
TOOLS & EQUIPMENT
CHECKLIST**



www.spanesi.com



About Spanesi Americas:

Spanesi Americas is a company created with the same passion and expertise Spanesi SpA has become known for globally since 1989. Spanesi Americas' mission is to bring new products and technologies to body shops in the Americas to enable technicians to perform repairs to a high standard of excellence.

Spanesi SpA is the leading international producer of automotive repair equipment and manufacturer of effective body shop solutions. Spanesi's product lines include: Straightening Benches, Multibenches, Touch Electronic Systems, Vacuum Systems, Welding Machines, Infrared Lamps, Lifts, Painting Tools, Spray Booth Equipment, and Manual, Pneumatic, Electric, and Hydraulic Tools.

For more details about Spanesi Americas products and solutions, contact Timothy Morgan, Managing Director, 123 Ambassador Drive, Naperville, IL, 60540, 1.224.SPANESI (772.6374) tmorgan@spanesi-americas.com, www.SPANESI.com.





106 BENCH 5000mm



Code	Description	YES	NO
90OSABP701	BENCH 5000MM LENGTH/LIFT 11,000LBS	<input type="checkbox"/>	<input type="checkbox"/>
90CS170080	230 V 1PH POWER UNIT	<input type="checkbox"/>	<input type="checkbox"/>
90PTIR0107	10 TON PULL TOWER W/HYD,CHAIN	<input type="checkbox"/>	<input type="checkbox"/>
90STAR0003	UNIVERSAL 'SUPERSTAR' JIG SET	<input type="checkbox"/>	<input type="checkbox"/>
90STARCRO5	RACKS KIT 5 METER (RAMPS)	<input type="checkbox"/>	<input type="checkbox"/>
90STARP004	KIT OF ACCENDING RAMPS	<input type="checkbox"/>	<input type="checkbox"/>
90KCAVA010	COUPLE OF SUPPORT TROLLEY FOR RAMPS	<input type="checkbox"/>	<input type="checkbox"/>
9000210B01	LOADING TROLLEY	<input type="checkbox"/>	<input type="checkbox"/>
9000210B11	REINFORCEMENT CROSS BAR SET	<input type="checkbox"/>	<input type="checkbox"/>

Code	Description
90SETAL010	Ergal (7075 Aluminium Alloy) Jig's Kit Apposite For Aluminium

YES NO



PISTA BENCH



Code	Description	YES	NO
90OSABPD01	BENCH 5000MM LENGTH/ LIFT 11,000LBS	<input type="checkbox"/>	<input type="checkbox"/>
90CS170080	230 V 1PH POWER UNIT	<input type="checkbox"/>	<input type="checkbox"/>
90PTIR0304	REVOLVING 10 T TOWER/W HYD,CH LEFT	<input type="checkbox"/>	<input type="checkbox"/>
90PTIR0303	REVOLVING 10 T TOWER/W HYD,CH RIGHT	<input type="checkbox"/>	<input type="checkbox"/>
90STAR0003	UNIVERSAL 'SUPERSTAR' JIG SET	<input type="checkbox"/>	<input type="checkbox"/>
90STARCRO5	RACKS KIT 5 METER (RAMPS)	<input type="checkbox"/>	<input type="checkbox"/>
90STARP004	KIT OF ACCENDING RAMPS	<input type="checkbox"/>	<input type="checkbox"/>
90KCAVA010	COUPLE OF SUPPORT TROLLEY FOR RAMPS	<input type="checkbox"/>	<input type="checkbox"/>
9000210B01	LOADING TROLLEY	<input type="checkbox"/>	<input type="checkbox"/>
9000210B11	REINFORCEMENT CROSS BAR SET	<input type="checkbox"/>	<input type="checkbox"/>
90VERSTM01	220 V ELECT WINCH	<input type="checkbox"/>	<input type="checkbox"/>

STRUCTURAL REPAIR EQUIPMENT

MULTI BENCH PACKAGE 1



Code	Description	YES	NO
92MINOSA44-1		<input type="checkbox"/>	<input type="checkbox"/>
90MINOSA44	BENCH W/ SCISSOR LIFT 6,600 LBS	<input type="checkbox"/>	<input type="checkbox"/>
90CMINI280	220 V 1PH POWER UNIT	<input type="checkbox"/>	<input type="checkbox"/>
80330700	RAMP SET RIGHT WHEELS	<input type="checkbox"/>	<input type="checkbox"/>
80330800	RAMP SET LEFT WHEELS	<input type="checkbox"/>	<input type="checkbox"/>

MULTI BENCH PACKAGE 2



STRUCTURAL REPAIR EQUIPMENT

Code	Description	YES	NO
90MINOSA44	BENCH W/ SCISSOR LIFT 6,600 LBS	<input type="checkbox"/>	<input type="checkbox"/>
90CMINI280	220 V 1PH POWER UNIT	<input type="checkbox"/>	<input type="checkbox"/>
80330700	RAMP SET RIGHT WHEELS	<input type="checkbox"/>	<input type="checkbox"/>
80330800	RAMP SET LEFT WHEELS	<input type="checkbox"/>	<input type="checkbox"/>
80470000	LOW MINIBENCH RAMPS	<input type="checkbox"/>	<input type="checkbox"/>

MULTI BENCH PACKAGE 2.5



Code	Description	YES	NO
90MINOSA44	BENCH W/ SCISSOR LIFT 6,600 LBS	<input type="checkbox"/>	<input type="checkbox"/>
90CMINI280	220 V 1PH POWER UNIT	<input type="checkbox"/>	<input type="checkbox"/>
80330700	RAMP SET RIGHT WHEELS	<input type="checkbox"/>	<input type="checkbox"/>
80330800	RAMP SET LEFT WHEELS	<input type="checkbox"/>	<input type="checkbox"/>
80470000	LOW MINIBENCH RAMPS	<input type="checkbox"/>	<input type="checkbox"/>
90MINKIT25	KIT OF 4 PINCH CLAMP	<input type="checkbox"/>	<input type="checkbox"/>

MULTI BENCH PACKAGE 3



Code	Description	YES	NO
90MINOSA44	BENCH W/ SCISSOR LIFT 6,600 LBS	<input type="checkbox"/>	<input type="checkbox"/>
90CMINI280	220 V 1PH POWER UNIT	<input type="checkbox"/>	<input type="checkbox"/>
80330700	RAMP SET RIGHT WHEELS	<input type="checkbox"/>	<input type="checkbox"/>
80330800	RAMP SET LEFT WHEELS	<input type="checkbox"/>	<input type="checkbox"/>
80470000	LOW MINIBENCH RAMPS	<input type="checkbox"/>	<input type="checkbox"/>
90PTiRO070	10 TON TOWER/HYD,CHAIN	<input type="checkbox"/>	<input type="checkbox"/>
90MINKIT25	KIT OF 4 PINCH CLAMP	<input type="checkbox"/>	<input type="checkbox"/>

STRUCTURAL REPAIR EQUIPMENT

MULTI BENCH PACKAGE 4



Code	Description	YES	NO
90MINOSA44	BENCH W/ SCISSOR LIFT 6,600 LBS	<input type="checkbox"/>	<input type="checkbox"/>
90CMINI280	220 V 1PH POWER UNIT	<input type="checkbox"/>	<input type="checkbox"/>
80330700	RAMP SET RIGHT WHEELS	<input type="checkbox"/>	<input type="checkbox"/>
80330800	RAMP SET LEFT WHEELS	<input type="checkbox"/>	<input type="checkbox"/>
80470000	LOW MINIBENCH RAMPS	<input type="checkbox"/>	<input type="checkbox"/>
90PTiRO070	10 TON TOWER/HYD,CHAIN	<input type="checkbox"/>	<input type="checkbox"/>
90MINKIT25	KIT OF 4 PINCH CLAMP	<input type="checkbox"/>	<input type="checkbox"/>
90MINKIT26	4 HIGH STIRRUP MOUNTS	<input type="checkbox"/>	<input type="checkbox"/>
9000210B14	KIT OF 4 WHEEL TROLLEY	<input type="checkbox"/>	<input type="checkbox"/>

MULTI BENCH PACKAGE 5



Code	Description	YES	NO
90MINOSA44	BENCH W/ SCISSOR LIFT 6,600 LBS	<input type="checkbox"/>	<input type="checkbox"/>
90CMINI280	220 V 1PH POWER UNIT	<input type="checkbox"/>	<input type="checkbox"/>
80330700	RAMP SET RIGHT WHEELS	<input type="checkbox"/>	<input type="checkbox"/>
80330800	RAMP SET LEFT WHEELS	<input type="checkbox"/>	<input type="checkbox"/>
80470000	LOW MINIBENCH RAMPS	<input type="checkbox"/>	<input type="checkbox"/>
90PTiRO070	10 TON TOWER/HYD,CHAIN	<input type="checkbox"/>	<input type="checkbox"/>
90MINKIT25	KIT OF 4 PINCH CLAMP	<input type="checkbox"/>	<input type="checkbox"/>
90MINKIT26	4 HIGH STIRRUP MOUNTS	<input type="checkbox"/>	<input type="checkbox"/>
9000210B14	KIT OF 4 WHEEL TROLLEY	<input type="checkbox"/>	<input type="checkbox"/>
90KFISS060	COMPLETE SET OF UNIVERSAL FIXTURE FOR CIAOBENCH WITH TROLLEY	<input type="checkbox"/>	<input type="checkbox"/>
90STARVIT4	SCREW SET	<input type="checkbox"/>	<input type="checkbox"/>
90KTRAV020	COUPLE OF CROSS BARS OF 1.800m FOR CLAMPS FOR VAN APPLICABLE ON MINIBENCH(ALL MODEL)/CIAOBENCH	<input type="checkbox"/>	<input type="checkbox"/>
90MINKIT27	ADJUSTABLE STIRRUPS SET	<input type="checkbox"/>	<input type="checkbox"/>
90MST002	RIGHT COMPLETE SLIDING BASE	<input type="checkbox"/>	<input type="checkbox"/>
90MST006	LEFT COMPLETE SLIDING BASE	<input type="checkbox"/>	<input type="checkbox"/>
90201925	WRENCH KIT FOR JIG	<input type="checkbox"/>	<input type="checkbox"/>

STRUCTURAL REPAIR EQUIPMENT

MULTI BENCH PACKAGE 6



Code	Description	YES	NO
90MINOSA44	BENCH W/ SCISSOR LIFT 6,600 LBS	<input type="checkbox"/>	<input type="checkbox"/>
90CMINI280	220 V 1PH POWER UNIT	<input type="checkbox"/>	<input type="checkbox"/>
80330700	RAMP SET RIGHT WHEELS	<input type="checkbox"/>	<input type="checkbox"/>
80330800	RAMP SET LEFT WHEELS	<input type="checkbox"/>	<input type="checkbox"/>
80470000	LOW MINIBENCH RAMPS	<input type="checkbox"/>	<input type="checkbox"/>
90PTiRO070	10 TON TOWER/HYD,CHAIN	<input type="checkbox"/>	<input type="checkbox"/>
90MINKIT25	KIT OF 4 PINCH CLAMP	<input type="checkbox"/>	<input type="checkbox"/>
90MINKIT26	4 HIGH STIRRUP MOUNTS	<input type="checkbox"/>	<input type="checkbox"/>
9000210B14	KIT OF 4 WHEEL TROLLEY	<input type="checkbox"/>	<input type="checkbox"/>
90KFISS060	COMPLETE SET OF UNIVERSAL FIXTURE FOR CIAOBENCH WITH TROLLEY	<input type="checkbox"/>	<input type="checkbox"/>
90STARVIT4	SCREW SET	<input type="checkbox"/>	<input type="checkbox"/>
90KTRAV020	COUPLE OF CROSS BARS OF 1.800m FOR CLAMPS FOR VAN APPLICABLE ON MINIBENCH(ALL MODEL)/CIAOBENCH	<input type="checkbox"/>	<input type="checkbox"/>
90MINKIT27	ADJUSTABLE STIRRUPS SET	<input type="checkbox"/>	<input type="checkbox"/>
90MST002	RIGHT COMPLETE SLIDING BASE	<input type="checkbox"/>	<input type="checkbox"/>
90MST006	LEFT COMPLETE SLIDING BASE	<input type="checkbox"/>	<input type="checkbox"/>
90201925	WRENCH KIT FOR JIG	<input type="checkbox"/>	<input type="checkbox"/>

MULTI BENCH TECHNICAL DATA

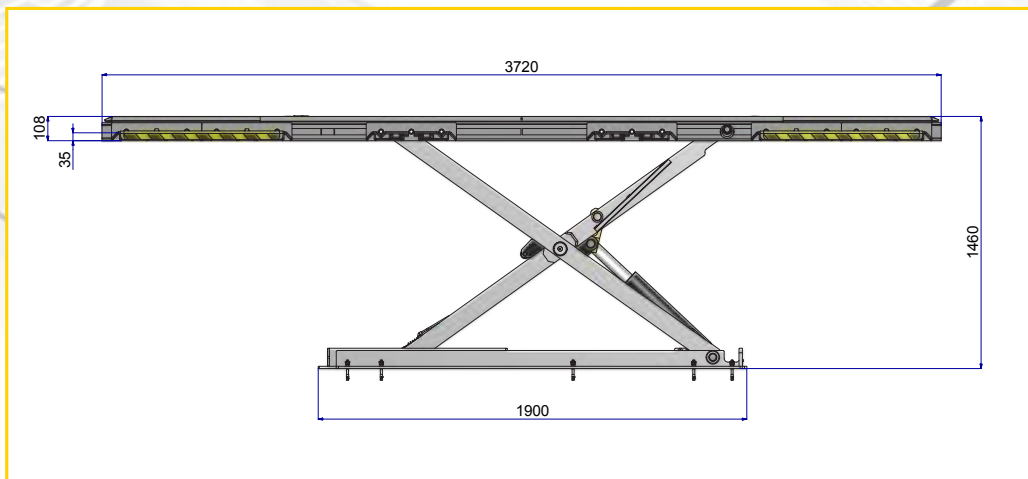
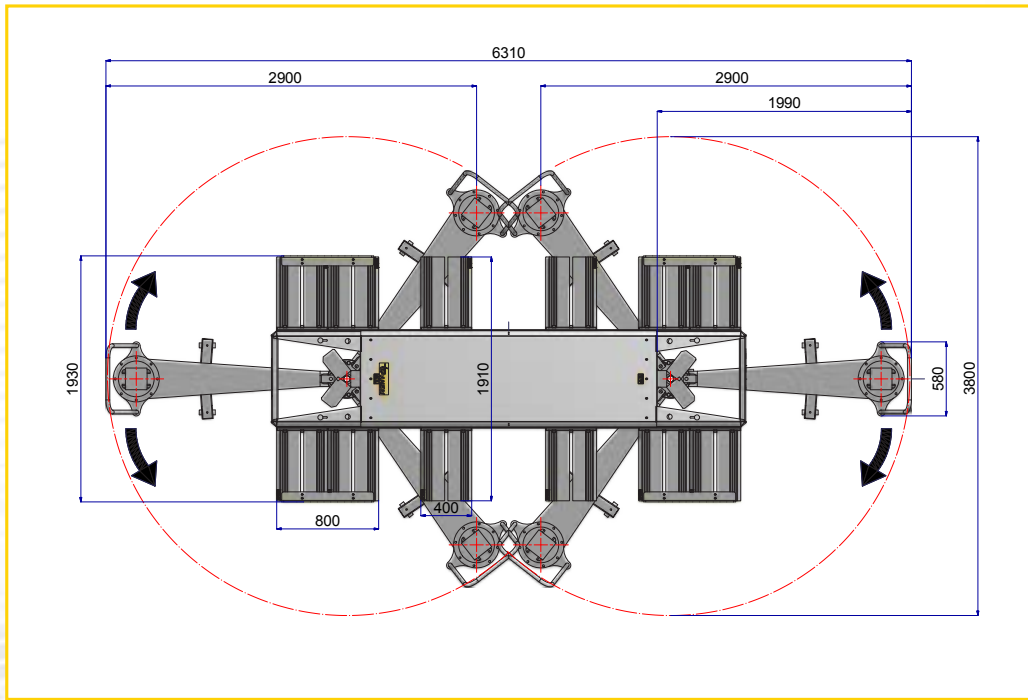

Max load	3000 Kg
Bench weight	955 Kg
Column weight	172 Kg
Control box weight	50 Kg
Lift time	62 sec.
Descent time	81 sec.
Voltage frequency	400 V - 50/60 Hz (*)
Pulling column capacity	10 t

(*) A richiesta voltaggio speciale / On request special voltage

STRUCTURAL REPAIR EQUIPMENT

TOUCH



More than 6000 vehicles present in our database

TOUCH VIRTUAL



Code	Description	YES	NO
90TOUCP080	TOUCH MEASURING SYSTEM	<input type="checkbox"/>	<input type="checkbox"/>
10000412	COMPLETE PC PACKAGE (LAPTOP PC, PRINTER,CABLES, SPEAKERS)	<input type="checkbox"/>	<input type="checkbox"/>
10000433-N	DATA SUBSCRIPTION (1 YEAR)	<input type="checkbox"/>	<input type="checkbox"/>
90TOUCV010	Touch Virtual	<input type="checkbox"/>	<input type="checkbox"/>

3D MEASURING EQUIPMENT

WHEEL ALIGNMENT EQUIPMENT



CROSS BAR FOR NOT SPANESI BENCHES

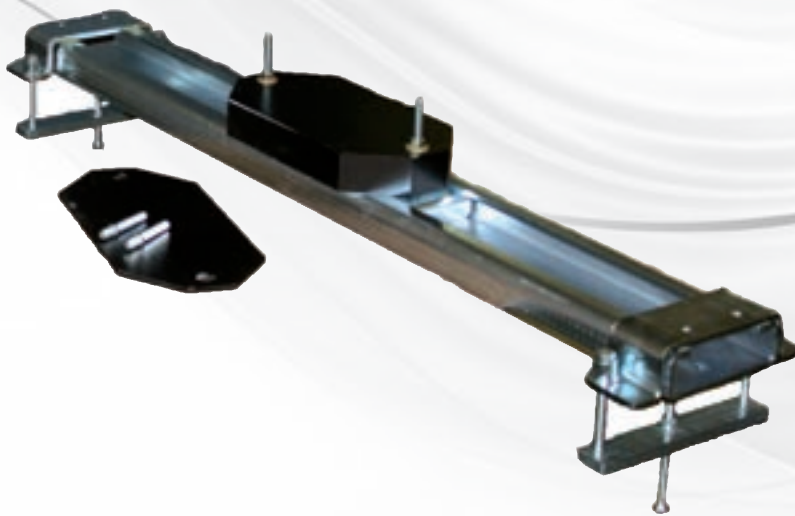

Code	Description	YES	NO
90KREGW010	TOUCH WHEELS - KIT FOR WHEELS ADJUSTMENT	<input type="checkbox"/>	<input type="checkbox"/>
90TOUCH6	SUPP. CROSS BAR FOR NOT SPANESI'S BENCHES	<input type="checkbox"/>	<input type="checkbox"/>

TOUCH ACCESSORIES

TECNA SPOT WELDER



Code	Description	YES	NO
92TECNA010	INVERTER CABLE MACHINE SPOT WELDER w SMART PLUS FEATURES 230 V AC w COOLER & BALANCER COVER AND USB SOFTWARE	<input type="checkbox"/>	<input type="checkbox"/>
3664P/200/60	WELDING MACHINE	<input type="checkbox"/>	<input type="checkbox"/>
8689	SHORT ARM FOR "C" GUN	<input type="checkbox"/>	<input type="checkbox"/>
5230	ELECTRODE HOLDER CAPS D	<input type="checkbox"/>	<input type="checkbox"/>
5328/W	SPECIAL WATER COOLED FI	<input type="checkbox"/>	<input type="checkbox"/>
8687 W/S	WATER COOLED LONG ARM	<input type="checkbox"/>	<input type="checkbox"/>

SPANESI SPOT WELDER



BRACCI PINZA/GUN'S ARMS "C"



Code	Description	YES	NO
90PUNTP117	INVERTER WELDING MACHINE 208V 3PH+ground 60Hz 14500A water cooled with automatic thickness recognition complete of trolley "c" gun 560 daN or 700 without arms	<input type="checkbox"/>	<input type="checkbox"/>
10000776	Arm for "c" gun complete with electrode 65mm art Xba210 cooled c-small	<input type="checkbox"/>	<input type="checkbox"/>
10000777	Arm for "c" gun complete with electrode 290mm art Xba215 cooled c-medium	<input type="checkbox"/>	<input type="checkbox"/>
10000778	Arm for "c" gun complete with electrode 590mm art Xba220 cooled c-large	<input type="checkbox"/>	<input type="checkbox"/>
10000743	Electrode caps, sphere point, for arm equipped with "c" gun art. E-280 xea060 (to buy with 1000075 electrode holder)	<input type="checkbox"/>	<input type="checkbox"/>
10000744	Electrode caps, radial point, for arm equipped with "c" gun art. E-287 xea016	<input type="checkbox"/>	<input type="checkbox"/>
10000745	Electrode holder for "c" gun art. Xpp-085 (for electrode 10000743)	<input type="checkbox"/>	<input type="checkbox"/>
10000634	Electrode central tip art. E-285 (1 pc = 20 units)	<input type="checkbox"/>	<input type="checkbox"/>

RESISTANCE SPOT WELDING EQUIPMENT

THREE TORCH GMA / MIG WELDER STEEL / ALUMINUM / SILICON BRONZE

MIG / GMA Welding Equipment



Code	Description	YES	NO
92CATAWELD_MIG_Q5	Torch for steel Torch for aluminum Torch for silicon bronze	<input type="checkbox"/>	<input type="checkbox"/>

- 5 WELD TORCHES TYPE
- 3 SPOOLS (WIRE OPTIONAL)
- 1 MIG TORCH X ALUMINIUM
- 1 MIG TORCH X STEEL
- 1 MIG TORCH X SILICON BRONZE
- 1 TIG TORCH (OPTIONAL)
- 1 MMA-STICK ELECTRODE
HOLDER (OPTIONAL)
- 2 REGULATION WITH HOSES

Technical data:
 INPUT VOLTAGE: 208/240V 30AMPS 50/60HZ SINGLE PHASE
 MMA-STICK: 10/200 A-20%
 TIG: 240 A-20%
 MIG: 240 A-20%
 PROTECTION: IP 22
 INSULATION: H

SINGLE TORCH Q3 GMA / MIG WELDER

MIG / GMA Welding Equipment



Spool gun and standard MIG torch
 Steel, aluminium, Silicone bronze, stainless
 Easy operating pre-set programs
 Programmable and self program storage
 with expandable memory
 Small or large spool capacity storage

Technical data:
 INPUT VOLTAGE: 208/240V 30AMPS 50/60HZ SINGLE PHASE
 MIG: 0-240 A-20%

Code	Description	YES	NO
92CATAWELD_MIG_Q3	Single Torch Q3 MIG Welder	<input type="checkbox"/>	<input type="checkbox"/>

Code	Description
SP249021	Manual mask with automatic obscuring helmet



YES NO

Code	Description	YES	NO	Code	Description	YES	NO
10SP280600	Wire coil Fe 0,6 mm - 5 kg	<input type="checkbox"/>	<input type="checkbox"/>	10000271	Wire coil Cusi 3 0,8 mm - 2 kg	<input type="checkbox"/>	<input type="checkbox"/>
10SP280800	Wire coil Fe 0,8 mm - 5 kg	<input type="checkbox"/>	<input type="checkbox"/>	10SP280000	Wire coil Cusi 3 1,0 mm - 5 kg	<input type="checkbox"/>	<input type="checkbox"/>



Code	Description	YES	NO	Code	Description	YES	NO
10SP288800	Wire coil AlSi 5% 1,0mm - 2kg	<input type="checkbox"/>	<input type="checkbox"/>	SP250004	Blanket for welding	<input type="checkbox"/>	<input type="checkbox"/>
SP248202	Wire coil AlMg 1,0 mm - 2 kg	<input type="checkbox"/>	<input type="checkbox"/>			<input type="checkbox"/>	<input type="checkbox"/>

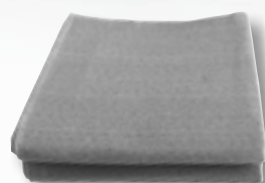

WELDING TOOLS



SPANESI
Spray Booths
Preparation Areas
Industrial Booths

SPRAY BOOTHS

PREPARATION AREAS

INDUSTRIAL BOOTHS



MICHELANGELO





RAFFAELLO





GIOTTO





5 rows of racks civil work basement



3 rows of racks civil work basement



Metal basement H=330



Metal basement with pneumatic ramp



Main front with stainless steel finishing



Double front



Side rolling door



Side rolling door with lights

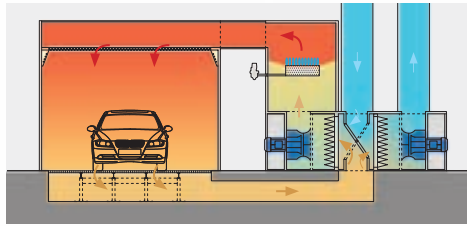
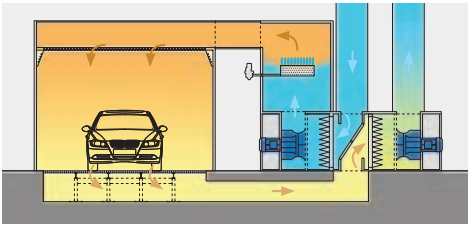

Booth insulation



Air-flow on spraying phase



Air-flow on drying phase



Gas appliances directive certification 2009/142/EC



LED lights

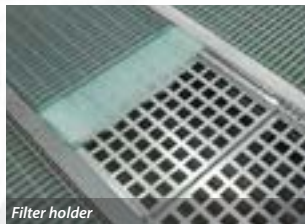

Filter holder



Direct fire burner

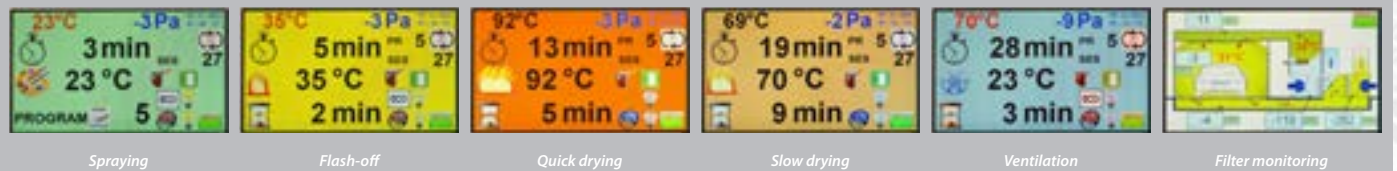

Spraying

Flash-off

Quick drying

Slow drying

Ventilation

Filter monitoring



Program number settings

Pr

On/Off

Settings for spraying phase temperature

Pr

Work period settings

Settings for flash-off phase temperature

Pr

Heating On/Off

Settings for quick drying phase temperature

Pr

Top lights On/Off

Settings for drying phase temperature

Pr

Bottom lights On/Off

Optional

F1

F2 Optional

Pressure/Temperature display

Pa

Eco "Economy" mode (only with inverters)

Start

Start

Stop

Menu access/Exit

SET

Enter



Heat exchanger stainless steel 2.5 mm

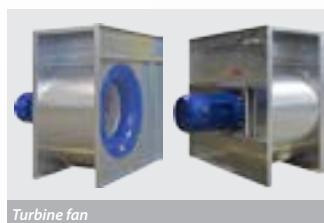

Turbine fan



Inverters

- User friendly control panel
- Temperature and pressure auto balance
- Consumption record data
- Economy function for energy saving

*



- STANDARD
- OPTIONAL
- NOT AVAILABLE

	MICHELANGELO		RAFFAELLO		GIOTTO	
USEFUL LENGHT	6,00 m	EXTERNAL LENGHT	6,11 m	○	○	○
USEFUL LENGHT	6,50 m	EXTERNAL LENGHT	6,61 m	○	○	○
USEFUL LENGHT	7,00 m	EXTERNAL LENGHT	7,11 m	●	●	●
USEFUL LENGHT	7,50 m	EXTERNAL LENGHT	7,61 m	○	○	○
USEFUL LENGHT	8,00 m	EXTERNAL LENGHT	8,11 m	○	○	○
USEFUL LENGHT	8,50 m	EXTERNAL LENGHT	8,61 m	○	—	○
USEFUL WIDTH	4,00 m	EXTERNAL WIDTH	4,11 m	●	●	●
USEFUL WIDTH	4,50 m	EXTERNAL WIDTH	4,61 m	○	○	○
USEFUL HEIGHT	2,70 m	EXTERNAL HEIGHT	3,40 m	●	●	●
USEFUL HEIGHT	3,00 m	EXTERNAL HEIGHT	3,70 m	○	○	○
USEFUL HEIGHT	3,20 m	EXTERNAL HEIGHT	3,70 m	○	○	○
USEFUL HEIGHT	3,50 m	EXTERNAL HEIGHT	4,00 m	○	○	—

FEATURES

- STANDARD
- OPTIONAL
- NOT AVAILABLE



	MICHELANGELO	RAFFAELLO	GIOTTO
INSULATED ROOF	○	—	○
3 ROWS OF 450 kg/wp RACKS CIVIL WORK BASEMENT	—	●	●
5 ROWS OF 450 kg/wp RACKS CIVIL WORK BASEMENT	●	○	○
5 ROWS OF 450 kg/wp RACKS METAL BASEMENT ¹	○	○	○
700 kg/wp RACKS	○	○	○
1000 kg/wp RACKS	○	○	○
PNEUMATIC INTERNAL RAMP ²	○	○	○
STEADY INTERNAL RAMP ²	○	○	○
EXTERNAL COUPLE OF RAMPS ²	○	○	○
THREE-DOOR MAIN ENTRANCE	—	—	●
FOUR-DOOR MAIN ENTRANCE	●	●	—
"MAXI" GLASSED FRONT WINDOWS	●	●	—

¹) Height=330mm

²) Only for H=330mm basements

- STANDARD
- OPTIONAL
- NOT AVAILABLE



				MICHELANGELO	RAFFAELLO	GIOTTO
MAIN FRONT WITH STAINLESS STEEL FINISHING				○	○	—
SIDE ROLLING DOOR				○	—	○
SIDE ROLLING DOOR WITH LIGHTS				○	—	—
SIDE SAFETY DOOR				●	○	○
BAR HANGER				●	●	●
BOTTOM LIGHTS				○	○	○
TOP LIGHTS				●	●	●
LED LIGHTS KIT				○	○	○
ENGINE POWER	7.5 + 7.5 kW	NOMINAL AIR-FLOW CAPACITY	25,000 m ³ /h	—	—	○
ENGINE POWER	11+11 kW	NOMINAL AIR-FLOW CAPACITY	34,000 m ³ /h	●	●	○
ENGINE POWER	15+15 kW	NOMINAL AIR-FLOW CAPACITY	38,000 m ³ /h	○	○	—
SYNOPTIC CONTROL PANEL				—	—	●

We'd like to remind you that for whatever specific need one might encounter you just have to contact Spanesi and inform them about your requirements; for sure Spanesi will be able to find the best technical solution at the lower investment cost

- STANDARD
- OPTIONAL
- NOT AVAILABLE



		MICHELANGELO	RAFFAELLO	GIOTTO
ELECTRONIC CONTROL PANEL		●	●	—
INVERTER MOTORS DRIVE		○	○	○
CLOGGED FILTERS ALARM (WITH DISPLAY)		○	—	—
AUTOMATIC PRESSURE BALANCE (ELECTRONIC)		●	○	○
SOFT-STARTER DEVICE		—	●	●
SINGLE STAGE DIESEL OIL BURNER	200 kW	—	—	○
TWO-STAGE GAS BURNER	280 kW	—	—	○
MODULATING DIRECT FIRE BURNER	280 kW	—	—	○
MODULATING DIRECT FIRE BURNER	420 kW	●	—	—
ENDOTHERMIC SYSTEM BY ELECTRIC RADIANT PANELS		—	●	—
SETTINGS FOR ACTIVATED COAL		○	○	○
REI 120 CUT FIRE DUMPER ³		●	—	●

³ UNI-EN 13501-3; EN 1366-2; D.M. 16/02/2007
(Optional for spray booths NOT installed in Italy)

SPRAY BOOTHS

PREPARATION AREAS

INDUSTRIAL BOOTHS

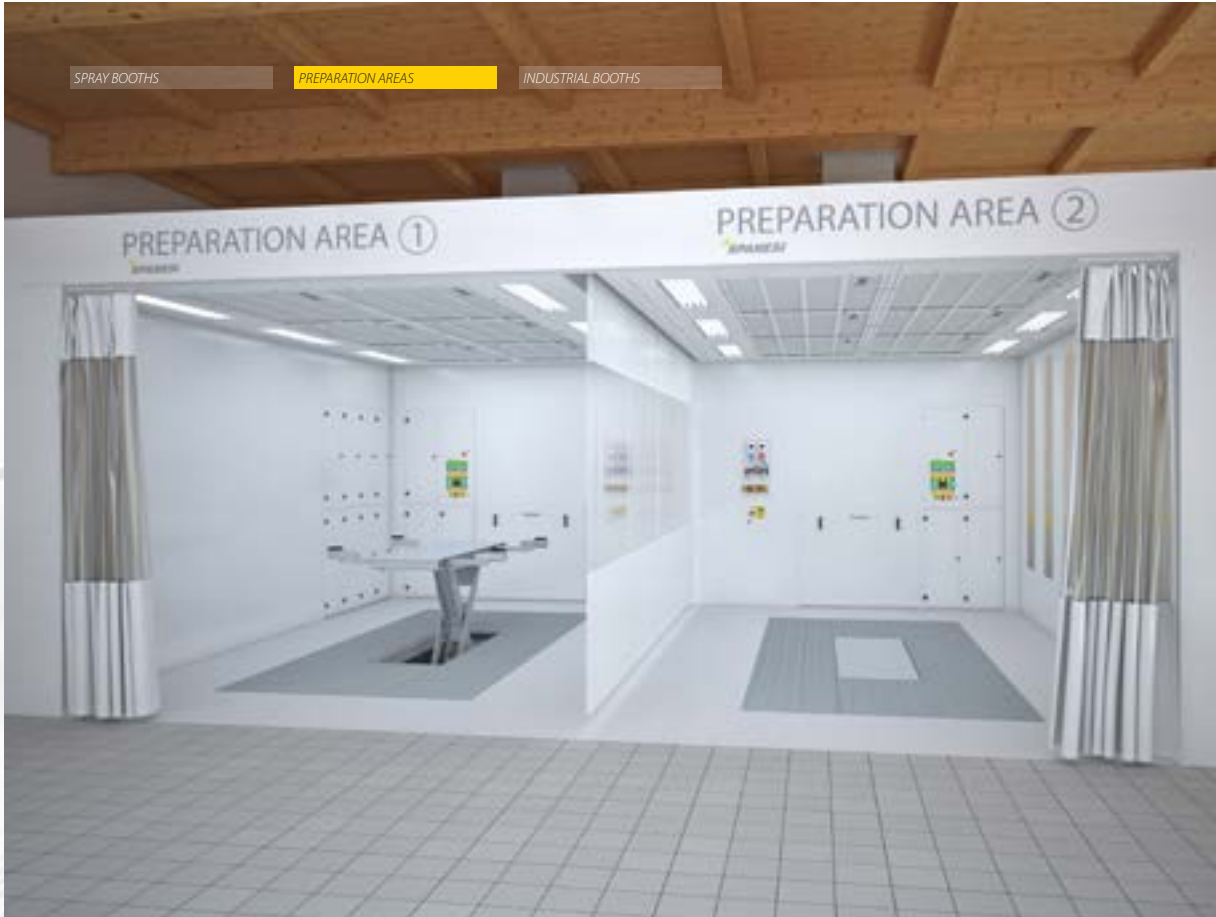



SPRAY BOOTHS

PREPARATION AREAS

INDUSTRIAL BOOTHS





Side extraction



Rear extraction



Four doors main entrance



Paint lift



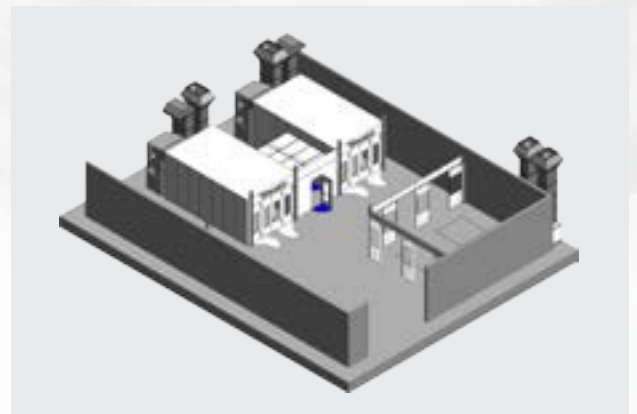
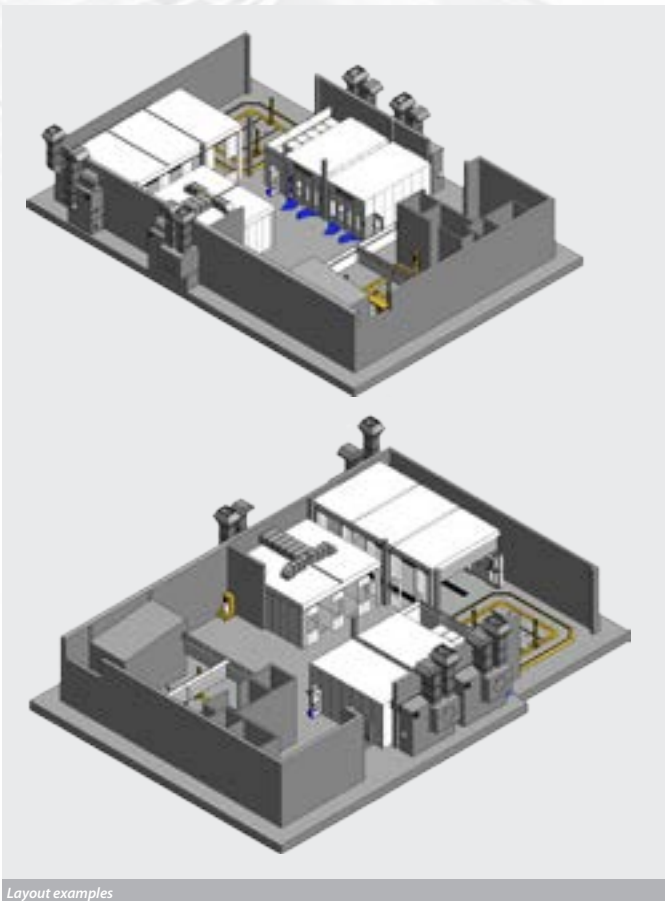

Layout examples

— *Sight of our production line, the most modern and TECHNOLOGICALLY ADVANCED in the world in the sector of spray booths and prep. areas manufacturing* —



WHERE THE BODY SHOP PROJECTS BECOME REALITY

To study, to plan and to organise the bodyshop. The importance of lay-out and know-how.

To be a consultant for the customer means to know how to create and how to plan the body shop.

For this reason Spanesi has created a technical office of planning, with the only purpose to realize complete layouts, for technological solutions which were planned keeping in consideration energy saving and environment protection.

The projects realized by Spanesi are clear and understandable, thanks to the use of the last software technologies, which allow to have the maximal visibility of the structure and of the included equipment.

*Thanks to our direct experience on the car repairation, it's easy to propose to our customers the **right solutions**.*

ONLY ONE PARTNER: SPANESI

We are the only company able to supply a turnkey bodyshop: everything except the walls!

*The advantage of having **one reference**, most of all when planning a new body shop, is fundamental.*

Spanesi thought about this because the customer never has to lose sight of the only important thing: the satisfaction of having the own dream realized.

We help the customer understanding his needs, beginning from the initial project, guiding him in all the phases, up to the body shop opening.

Fortified by its complete range, Spanesi offers everything you need for the body shop.

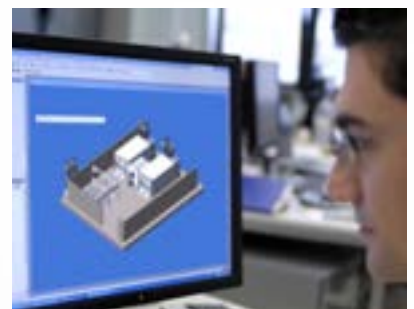



SPANESI
ALUMINIUM TOOLS

Code	Description
SP701001	7 Drawers trolley start 7

YES NO



Can-holder.



Handle for perfect mobility.



Roll support.*



Metal lock. Boxes with safety lock.



Telescopic guide.



Wheels with brake.

Code	Description
SP701025	Form of files

YES NO

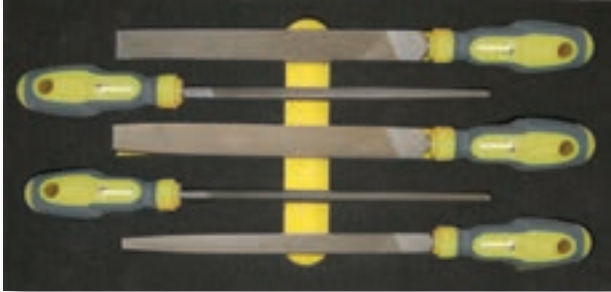

Code	Description
SP701017	Form of sockets and ratchets 1/4"

YES NO



SP70101020	Form of screwdriver slotted and phillips tips
------------	---

YES NO



SP701018	Form 22 1/2" Pieces
----------	---------------------

YES NO



SP701019	Form of 43 sockets 1/2" and 1/4"
----------	----------------------------------

YES NO



Code	Description
SP704212	Flexible magnetic extractor 600 mm (1 Kg Extraction capacity)

YES NO



Code	Description
SP701100	Tools not included

YES NO



Code	Description
SP702051	16 PCS of combined wrenches kit

YES NO

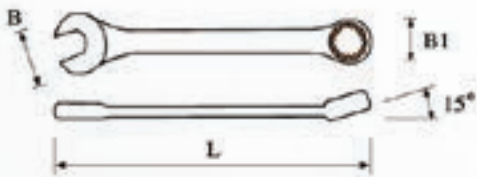
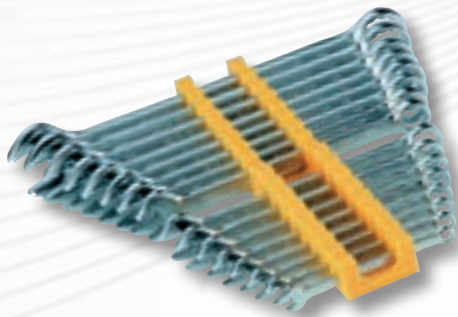

YES	NO
<input type="checkbox"/>	<input type="checkbox"/>
<input type="checkbox"/>	<input type="checkbox"/>
<input type="checkbox"/>	<input type="checkbox"/>
<input type="checkbox"/>	<input type="checkbox"/>
<input type="checkbox"/>	<input type="checkbox"/>
<input type="checkbox"/>	<input type="checkbox"/>
<input type="checkbox"/>	<input type="checkbox"/>
<input type="checkbox"/>	<input type="checkbox"/>
<input type="checkbox"/>	<input type="checkbox"/>
<input type="checkbox"/>	<input type="checkbox"/>
<input type="checkbox"/>	<input type="checkbox"/>
<input type="checkbox"/>	<input type="checkbox"/>
<input type="checkbox"/>	<input type="checkbox"/>
<input type="checkbox"/>	<input type="checkbox"/>
<input type="checkbox"/>	<input type="checkbox"/>
<input type="checkbox"/>	<input type="checkbox"/>
<input type="checkbox"/>	<input type="checkbox"/>
<input type="checkbox"/>	<input type="checkbox"/>
<input type="checkbox"/>	<input type="checkbox"/>
<input type="checkbox"/>	<input type="checkbox"/>
<input type="checkbox"/>	<input type="checkbox"/>
<input type="checkbox"/>	<input type="checkbox"/>
<input type="checkbox"/>	<input type="checkbox"/>
<input type="checkbox"/>	<input type="checkbox"/>
<input type="checkbox"/>	<input type="checkbox"/>

		B-B1	L	Weight	U / C
SP702052	6	15,5-10,1 mm	105 mm	17 g	12
SP702053	7	17,0-11,5 mm	115 mm	19,6 g	12
SP702054	8	19,2-12,8 mm	125 mm	26 g	12
SP702055	9	21,2-14,2 mm	135 mm	34 g	12
SP702056	10	23,2-15,6 mm	145 mm	36 g	12
SP702057	11	25,3-16,9 mm	155 mm	44 g	12
SP702058	12	27,2-18,3 mm	165 mm	52 g	12
SP702059	13	29,4-19,7 mm	175 mm	63 g	12
SP702060	14	31,5-21,2 mm	185 mm	78 g	12
SP702061	15	33,2-22,5 mm	195 mm	94 g	12
SP702062	16	34,7-24,0 mm	205 mm	105 g	12
SP702063	17	36,5-25,3 mm	215 mm	132 g	12
SP702064	18	38,7-26,8 mm	225 mm	144 g	12
SP702065	19	40,7-28,1 mm	235 mm	154 g	12
SP702066	20	43,1-29,7 mm	245 mm	188 g	12
SP702067	21	44,8-31,3 mm	255 mm	200 g	12

OPTIONAL					
SP702068	22	46,9-32,6 mm	265 mm	220 g	12
SP702069	24	50,4-35,5 mm	285 mm	285 g	6

Code	Description
SP705001	Round flat head hammer D40 curved mount 14X3



YES NO

Code	Description
SP705003	Round flat head D33-square flat 25



YES NO

Code	Description
SP705002	Round flat head hammer D40 mount



YES NO

Code	Description
SP705006	Hammer 600 g



YES NO

Code	Description
SP705005	Round rock point with gum hammer



YES NO

Code	Description
SP705034	Aluminium 4 hammers kit



YES NO

Code	Description
SP705007	Hammer with nylon head



YES NO

Code	Description
SP705151	Automatic Punch



YES NO

Code	Description
SP705121	Set of punches and chisels 6 pcs



YES NO

Code	Description
SP705201	Chisel with handle 230mm



YES NO

SPANESI ALUMINIUM TOOLS

Code	Description
SP705220	Handle for carrying files and for panel beater

YES NO



Code	Description
SP705222	Files for panel beater

YES NO



Code	Description
SP705211	Saw for blade 300mm

YES NO



Code	Description
SP705241	Flat block

YES NO



Code	Description
SP705243	Block with rail

YES NO



Code	Description
SP705244	Comma shaped anvil

YES NO



Code	Description
SP705261	Double point, double curve lever

YES NO



Code	Description
SP705263	Lever double medium curve

YES NO



Code	Description
SP705265	Medium lever curve face

YES NO



Code	Description
SP705267	Medium Lever Half Curved

YES NO



Code	Description
SP705268	Heavy lever without double curve

YES NO



Code	Description
SP706001	200mm Long Nose Plier

YES NO

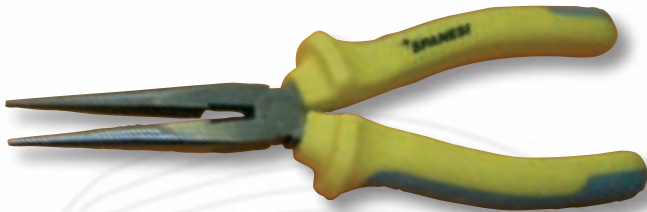

Code	Description
SP706003	200mm Universal Plier

YES NO



Code	Description
SP706111	End Cutting Nippers

YES NO



Code	Description
SP706131	Left Shears

YES NO

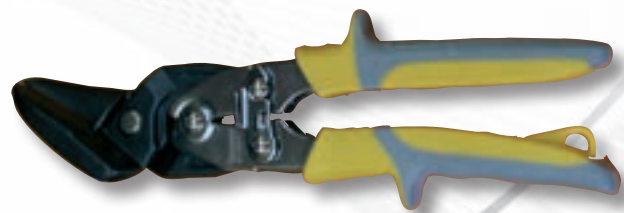

Code	Description
SP706132	Right Shears

YES NO



SPANESI ALUMINIUM TOOLS

Code	Description
SP706203	"LL" 15x42x35-215mm Kind Of Adjustable Plier

YES NO



Code	Description
SP706204	"W" 20X70x40-205mm Kind Of Adjustable Plier

YES NO



Code	Description
SP706205	"JJ" 26x45x50-230mm Kind Of Adjustable Plier

YES NO



Code	Description
SP706206	"L" 21x19x16-200mm Kind Of Adjustable Plier

YES NO



Code	Description
SP706202	"J" 30x25x8-215mm Kind Of Adjustable Plier

YES NO

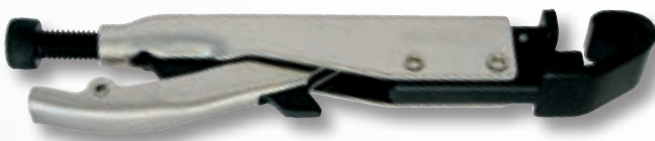

Code	Description
SP706219	Micro Grip Plier

YES NO

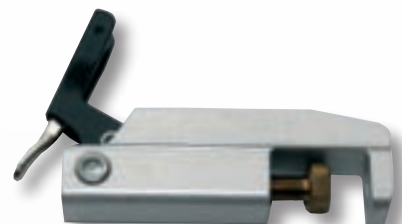

Code	Description
SP706215	"C" Shaped Lock-Grip Plier 18"

YES NO



Code	Description
SP706210	"C" Shaped Lock-Grip Plier 11"

YES NO



Code	Description
SP706211	Straight Lock-Grip Plier 10"

YES NO



Code	Description
SP706220	Lock-Grip Plier Concave Jaws 10"

YES NO



Code	Description
SP707161	Points remover kit

YES NO



Code	Description
SP708171	Set of knives

YES NO



P708172 Kit 10 Knives 12 mm (A)
 SP708173 Kit 10 Knives 16 mm (B)
 SP708174 Kit 10 Knives 20 mm (C)

Code	Description
SP707121	3 Bits For Drill Double Cut Streaked

YES NO



Code	Description
SP707151	Bits For Points Remover 6,5mm

YES NO



Code	Description
SP707152	Bits For Points Remover 8Mm

YES NO



Code	Description
SP711001	Spot Weld Drill

YES NO



Speed	2.000 rpm.
-------	------------

EQUIPMENT	UNIT
Drill bit 8mm	2
Drill bit 6.5 mm	2
Rotating head	1
Air filter	1
Male connection	1
Hexagonal spanner	1

Code	Description
SP711101	Pneumatic saw kit with blades and files

YES NO



Run	9500 bpm.
Path	10 mm.

EQUIPMENT	UNIT
Knife 32 teeth	5
Knife 24 teeth	5
Limes with teeth 3 mm	5

LOW VIBRATION

Code	Description
SP708202	Riveter For Rivets And Thread Rivets

YES NO



Code	Description
SP711113	Saws

YES NO



Code	Description
SP711301	Pneumatic Reveting Kit



YES NO

HEAD FOR RIVETS	
	4,8 mm (3/16")
	4 mm (5/32")
	3,2 mm (1/8")
	2,4 mm (3/32")

Code	Description
SP711312	Angular Pneumatic Griding And Sanding Kit



YES NO

SPEED	18.000 rpm
EQUIPMENT	UNIT
gridstone	10
abrasive fibre paper	10
adaptor for abrasive fibre paper	2
spanners	2
male connection	1

Code	Description
SP711331	Radial sander kit with equipments 3"

YES NO

SPEED	10.000 rpm
-------	------------



Code	Description
SP711602	Small Radial

YES NO

SPEED	12.000 rpm
DISC DIMENSION	4 - 1/5" (115 mm)



	UNIT
ADAPTER	2

Code	Description
SP711701	Wide-band sander

YES NO



Code	Description
SP711702	Tight-band sander

YES NO



Code	Description
SP711901	Reversible Drill

YES NO



Code	Description
SP762031	Electronic Protection Earphone

YES NO



<i>SPEED</i>	1.800 rpm
<i>BITCHUCK</i>	10 mm

Code	Description
SP709361	Paint thickness gauge

YES NO



Code	Description
SP709007	Measuring Tape 5 m

YES NO



SPOT REPAIR ALUMINIUM TROLLEY KIT

ALU KIT

90KALSP010

230V - 50/60Hz

90KALSP020

110V - 60Hz



Code	Description	Quantity	YES	NO
90KALSP010	Aluminium trolley kit Spanesi complete and with Spotter 230V 50/60Hz	1	<input type="checkbox"/>	<input type="checkbox"/>

Code	Description	Quantity	YES	NO
90KALSP020	Aluminium trolley kit Spanesi complete and with Spotter 110V 60Hz	1	<input type="checkbox"/>	<input type="checkbox"/>

SPOT REPAIR

SPOT REPAIR ALUMINIUM

TROLLEY KIT COMPONENTS

ALU KIT



COD.
10000872 230V - 50/60 Hz
10000874 110V - 60Hz

YES NO



COD.
10000789
 YES NO



COD.
10000787+10000788

YES NO



COD.
10000791
 YES NO



COD.
10000790
 YES NO



COD.
10000793
 YES NO



COD.
10000792
 YES NO



YES NO

COD.
10000796
SP231303
10000798
10000799

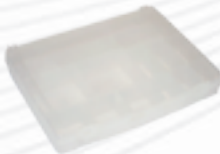

COD.
10000794
 YES NO



COD.
SP231304
SP231306
 YES NO



COD.
10000795
 YES NO

OPTIONAL



COD.
SP709351
 YES NO



COD.
SP705220
 YES NO



COD.
SP711312
 YES NO

SPOT REPAIR

SPOT REPAIR ALUMINIUM

TROLLEY KIT COMPONENTS

Code	Description	Quantity	YES	NO
10000872	Digital Aluminium spotter 230V 50/60 Hz art. TSW1500/CAR	1	<input type="checkbox"/>	<input type="checkbox"/>
10000874	Digital Aluminium spotter 110V 60 Hz art. TSW1500/CAR	1	<input type="checkbox"/>	<input type="checkbox"/>
10000787	Trolley for alu/steel kit (MWM 31460SPN) empty	1	<input type="checkbox"/>	<input type="checkbox"/>
10000788	Slide hammers holder kit for Alu/still kit trolley (MVM 3146020SPN)	1	<input type="checkbox"/>	<input type="checkbox"/>
10000790	Pulling bar kit 0,83m single foot with tie rod (MWM 32400)	1	<input type="checkbox"/>	<input type="checkbox"/>
10000792	Contact mas 4,5m for hammer(MWM33051154) ==Gun not includede==	1	<input type="checkbox"/>	<input type="checkbox"/>
10000794	Plastic case for elecrodos empty-(MWM 30920)	1	<input type="checkbox"/>	<input type="checkbox"/>
SP231304	Pulling ring m4 al/si(1 BOX=5 PCS) 010986 (MWM 30354)	1	<input type="checkbox"/>	<input type="checkbox"/>
SP231306	Pulling ring m5 al/si(1 BOX=5 PCS) 010987 (MWM 30355)	1	<input type="checkbox"/>	<input type="checkbox"/>
10000795	Kit of 6 wedges and extensions – (MWM 31200)	1	<input type="checkbox"/>	<input type="checkbox"/>
10000789	Set aluminium hammers in casebox - 4pcs. (MWM800150)	1	<input type="checkbox"/>	<input type="checkbox"/>
10000791	Pull system per alluminio (MWM 34102)	1	<input type="checkbox"/>	<input type="checkbox"/>
10000793	Accessories Kit For Aluminium SPANESI (MWM 30961 SPN)	1	<input type="checkbox"/>	<input type="checkbox"/>
10000796	Kit 100 screws AIMg3M14x16 (MWM 30101416)	1	<input type="checkbox"/>	<input type="checkbox"/>
SP231303	Threated pin M4x16AL/SI (1 BOX = 100 PCS) 010972 (MWM 30201416)	1	<input type="checkbox"/>	<input type="checkbox"/>
10000798	Kit 100 screws AIMg3M 5x20(MWM 30101520)	1	<input type="checkbox"/>	<input type="checkbox"/>
10000799	Kit 100 screws AISi12 M 5x20(MWM 30201520)	1	<input type="checkbox"/>	<input type="checkbox"/>
SP709351	Digital infrared thermometer range -20°C +500°C, distance 800mm	1	<input type="checkbox"/>	<input type="checkbox"/>
SP705220	Handle for files + file for panel beater	1	<input type="checkbox"/>	<input type="checkbox"/>
SP711312	Angulare pneumatic griding and sanding kit- SPEED 18.000rpm-10 Gridstone-°10 Abrasive fibre paper - 2 spanners-1 male connector	1	<input type="checkbox"/>	<input type="checkbox"/>

SPOT REPAIR

SPOT REPAIR ALUMINIUM

OPTIONAL KIT

ALU KIT OPTIONAL 10000877

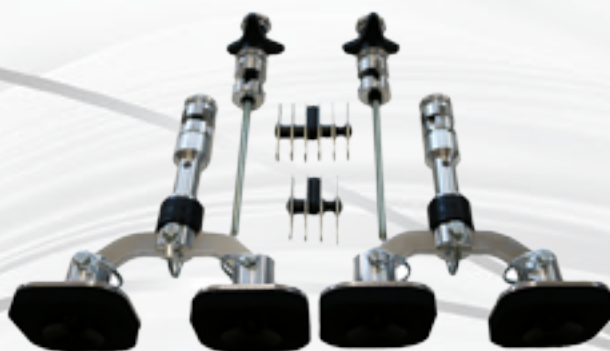

COD.
10000814



COD.
10000811



COD.
10000813



COD.
10000812

Code	Description	Quantity	YES	NO
10000877	Aluminium optional kit Spanesi complete (MWM 32292SPN)	1	<input type="checkbox"/>	<input type="checkbox"/>
10000814	Universal mobile foot kit for pullong bar complete with 2 bases 100X100 with suction cups (MWM 32292BRI)	2	<input type="checkbox"/>	<input type="checkbox"/>
10000811	Tie-Rods with slider for pulling bar (MWM 32293)	2	<input type="checkbox"/>	<input type="checkbox"/>
10000813	6 hooks gripping head M10 (MWM 37165)	1	<input type="checkbox"/>	<input type="checkbox"/>
10000812	4 hooks gripping head M10 (MWM 37164)	1	<input type="checkbox"/>	<input type="checkbox"/>

YES NO

SPOT REPAIR



Designed specifically for the capture of live sparks, embers and combustible dust, like aluminium and titanium, the Barracuda's powerful vacuum motor draws air and collected particulate into the immersion tank, and forces it through a roiling water bath, instantly quenching sparks, and thoroughly wetting dust out of the airstream. Three stages of additional filtration ensure that the air exhausted from the system is dust and moisture free.

When its time to empty the tank, simply pull the valve lever to dump the water and debris out through a filter sock and into any floor drain. Once the tank is empty, connect the system to a normal garden hose and a series of spray heads inside the unit continue to flush the tank, ensuring that no sediment builds up on the internal components. The large window makes it simple to confirm the water level in the tank, and allows spectators to view the carnage as dust and debris gets consumed by the Barracuda.

Features:

- * 2 Users
- * All stainless steel construction will never rust
- * Multi nozzle internal wash down system keeps the unit clean
- * Large window to monitor water level and vacuum activity
- * 4 stage filtration system ensures dust containment
- * Drain filter for easy collection and disposal of sludge

Code	Description	YES	NO
BARRACUDA	Barracuda Two User immersion Vac / Separator	<input type="checkbox"/>	<input type="checkbox"/>

TYPHOON



YES NO

Code	Description
903BALU010	Vacuum unit mod. Typhoon 3B for aluminium (3kW) with antistatic filters

OPTIONAL:

YES NO



SP767032 2,5mm
Palm sander

YES NO



90SF0113 - 5m ANI -
90SF0115 - 6m ANI -
Flexible air tube Ø 29



External height 3,80 m / internal 3,54 m

External width 5,10 m / internal 5,00 m

External length 8,10 m / internal 8,00 m

Single frontal with 4 wings with "maxi" glazed windows (useful passage: width. 3,6 M - h 3,51 m)

Self-supporting structure by galvanized prevarnished white ral 9003 sheet

"Sandwich" type with insulation with glass wool (thickness 52mm)

Ceiling filter to input air

100% Polyester fiber thermofixed - thickness 20mm - weight 200gr/m²

Filtering 90,1% -storage capability 494 gr/m²

Conduct to flame b2 din 4102 teil 1 (self-extinguishing)



ALUMINIUM BAY type 3

Lighting with 2 rows of lights by built-in ceiling fixed between perimeter panel and roof - no. 8
With 4 tubes x 58w each + no. 4 With 4 tubes x 30w each
Wide customization in terms of lateral service door, storage cabinets and possible glazed windows (normal or "maxi") on perimetral panels



Vacuum channels with a floor surface filter (double filter)

1) Metallic mesh layers made of knit-cuspided aluminium - class eu2
Thickness 10mm - filtering 65% -
maximum operating temp. 200° C
Recommended final pressure drop 150pa
- related humidity maximum 100%

2) Medium progressive type polyester -
reaction to fire f1 din 53438 - cl. Eu4
Thickness 23mm - filtering 90% -
maximum operating temp. 100° C
Recommended final pressure drop 250pa
-related humidity maximum 100%



ALUMINIUM BAY type 3

Nr. 2 Electric centrifugal - 0,37 kw - 1400 rev / min (230/400v 50hz - atex)
Control panel for lights and ventilation
(Fans power on delay of a few seconds than turning on lights)



Vacuum unit mod. 3B for aluminiumo 3 kw with antistatic filters



Column "trial" with integrated system of dust suction, electrical power and compressed air



ALUMINIUM BAY type 3

Scissor bench 5m "tiger" with lift (h max 1550 mm - portata 5000kg)

Control box 400v 3f 50hz 2,2kw for infloor bench

Racks for 5m spanesi bench

Universal jig "superstar" with no.6 Cross bars length 1800mm. No.10 Sliding supports and trolley with accessories. Cd-rom winstar and semestral user licence of data sheets



Mcperson measuring system for shock absorber and comparative measurements

Pulling column with pulling kit 6t c300

Loading trolley for lift series 100 with sl170

Kit 5mt. Ramps + pneumatic springs for cover hollow on tiger infloor

Kit of 12 positioning platforms for tiger infloor

Couple of blocks for trolley for tiger and 106 embedded benches (complete with sliding support plugs)



ALUMINIUM BAY type 3

RIVET GUN



CODE: 50112964



CODE: 50106668

Code	Description	Quantity	YES	NO
90RIBAT010	Rivet gun complete with pillars, rivets and handbag Depth of the "C" 30 mm (included)	1	<input type="checkbox"/>	<input type="checkbox"/>
OPTIONAL:				
50112964	"C" pliers for rivet gun depth 220 mm	1	<input type="checkbox"/>	<input type="checkbox"/>
50106668	"C" pliers for rivet gun depth 110 mm	1	<input type="checkbox"/>	<input type="checkbox"/>

RIVET GUN



MV Marketing und Vertriebs-GmbH & Co.KG
Wieländer+Schill
Professionelle Karosserie-Spezialwerkzeuge

ALUMINIUM TOOLS FOR

 ***SPANESI***®

Code	Description
10SP871K00	Type-Approved Wielander+Schill Trolley Complete With Accessories

YES NO



Code	Description
10SP870000	Trolley for aluminum repair dim. 1000X620x890mm r230 Without tools (881201)

YES NO



Code	Description
10SP561150	Vice Grip 112 5"

YES NO



Code	Description
10SP561151	Vice Grip 145 12"

YES NO



SPANESI®
 FOR
ALUMINIUM TOOLS

Code	Description
10SP561186	Micro-grip Clamp 2000

YES NO



Code	Description
10SP561154	Vice Grip 111 10" (561154)

YES NO



Code	Description
10SP561230	Vice Clamp Length 300mm

YES NO



Code	Description
10SP511110	Oblique Dolly 1200g

YES NO



Code	Description
10SP511112	Universal Dolly

YES NO



Code	Description
10SP865100	Polyamide Moulding Wedge

YES NO



Code	Description
10SP865200	Large Polyamide Moulding Wedge

YES NO



Code	Description
10SP865300	Grey Polyamide Assembling Wedge

YES NO



Code	Description
10SP871200	Round Brush G10 (541101)

YES NO



Code	Description
10SP871300	Flat Brush G5 (541103)

YES NO



Code	Description
10SP871100	Manual Countersink Tool

YES NO



Code	Description
10SP871400	Replacement Blades For Countersink

YES NO



Code	Description
10SP871600	Cartridges Pistol 3m Epx

YES NO



Code	Description
10SP511027	Wooden Hammer

YES NO



Code	Description
10SP511030	Aluminum Embossing's Hammer

YES NO



Code	Description
10SP511031	Recoiling Hammer

YES NO



Code	Description
10SP511039	Finishing And Grooving Hammer 300g

YES NO



Code	Description
10SP800200	Hot Air Dryer 3000w (Leister) (801200)

YES NO



Code	Description
10SP868200	Protector Blanket For Grinding Sparks Dim.2500x1250mm (881002)

YES NO



Code	Description
10SP868300	Protector Blanket For Welding Dim.2000x1500mm

YES NO



Code	Description
10SP867000	Complete Kit To Labor Aluminum (Alu Pull Kit Ak98/361000)

YES NO



Code	Description
10SP879100	Round Stainless Steel Brush Ø75mm (541202)

YES NO



Code	Description
10SP879200	Round Stainless Steel Brush Thin Ø80mm (541201)

YES NO



Code	Description
10SP879300	Spatulas Stainless Steel 4 U. (541020)

YES NO



Code	Description
10SP879400	Plastic Seal For Aluminum (2 U.) (542050) ***Imo***

YES NO



Code	Description
10SP311050	Red Diffuser For Control With Penetrating Fluid 400ml ***Imo***

YES NO



Code	Description
10SP311051	Detergent For Control With Penetrating Fluid 400ml ***Imo***

YES NO



Code	Description
10SP311052	Thermodiffusor Revealing For Control With Penetrating Fluid 400ml ***Imo***



YES NO

Code	Description	YES	NO
10SP571110	Pneumatic Rivet Gun 'Taurus 4' (571110)	<input type="checkbox"/>	<input type="checkbox"/>
10SP578114	Extention 100mm For 'Taurus 4' (578114)	<input type="checkbox"/>	<input type="checkbox"/>



Code	Description
10SP577107	Needle Screw Ø6,35mm (20pcs)



YES NO

Code	Description	YES	NO
10SP617227	Special Cutter Tin 6,5 For Rivets	<input type="checkbox"/>	<input type="checkbox"/>



YES NO

Code	Description
10SP617240	Counterbore 120° Unit With Pilot



YES NO

Code	Description	YES	NO
10SP512001	Chisel With Handle For Car Body	<input type="checkbox"/>	<input type="checkbox"/>



YES NO



Code	Description
10SP521231	Right Chassis Wooden File

YES NO

Code	Description
10SP881320	Flexible Rod With Magnetic End 2371800mm

YES NO

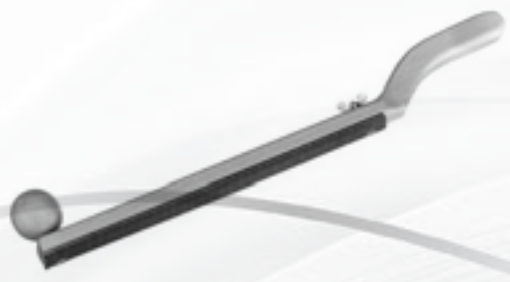

Code	Description
10SP700001	Rivet Tool Xpress-800 Standard Set Modular Fastener System With Innovative pneumo Hydraulic Pressure Ratio

YES NO



Code	Description
10SP700002	Rivet System Xpress 800 Full Set

YES NO



- Consists Of:**
- Basic Unit
 - Power Cylinder Ssc35/25
 - C-Arm Gc 80/40
 - C-Arm Gc 80/120
 - C-Arm Gc 140/240
 - Blind Rivet Adapter Br20 (20kn)
 - Blind Rivet Adapter Br50 (50kn)
 - Blind Rivet Nuts Adapter Brn20 (50kn)
 - Tool Set Rs-03
 - Tool Set Rs-04

Code	Description
10SP700203	Tool Box Rs-06 Version Jaguar Land Rover

YES NO



WELDING FUME EXTRACTOR

WELDING FUME EXTRACTOR



TECHNICAL DATA:	UNIT
Flow rate	2500 m ³ /h
Operating flow rate	1480 m ³ /h
Filtration efficiency	EH 1822 (H12) /99.5 rule/%
Filtration surface	14.5 m ²
Engine power	1.1 kw - 220V 50Hz
Sound	20
Width	105 Kg

Code	Description
10000756	Portable exhaust welding fumes

YES NO

INFRARED LAMPS



YES NO

Code	Description	Quantity
90MAREA106	MAREA 1 infrared lamp, short waves, 3 candles, nominal tension: 230V 50/60Hz, nominal power: 3x1200W (with trolley)	1

INFRARED LAMPS

SPANESI AMERICAS INC.
123 Ambassador Dr., Suite 107
Naperville IL 60540
Ph: 1.224.SPANESI (772-6374)
sales@spanesi-americas.com
www.spanesi.com

follow us on    

The data, product color and pictures in this catalogue are for illustrative purpose only. Spanesi reserves the right to make changes without notice.